

DASH POD

INSTALLATION INSTRUCTIONS



Superchips

PARTS INCLUDED

1997-2006 TJ WRANGLER KIT

- ① DASH POD
- ② RUBBER GROMMET
- ③ SELF TAPPING SCREWS
- ④ ZIP-TIES (NOT SHOWN)

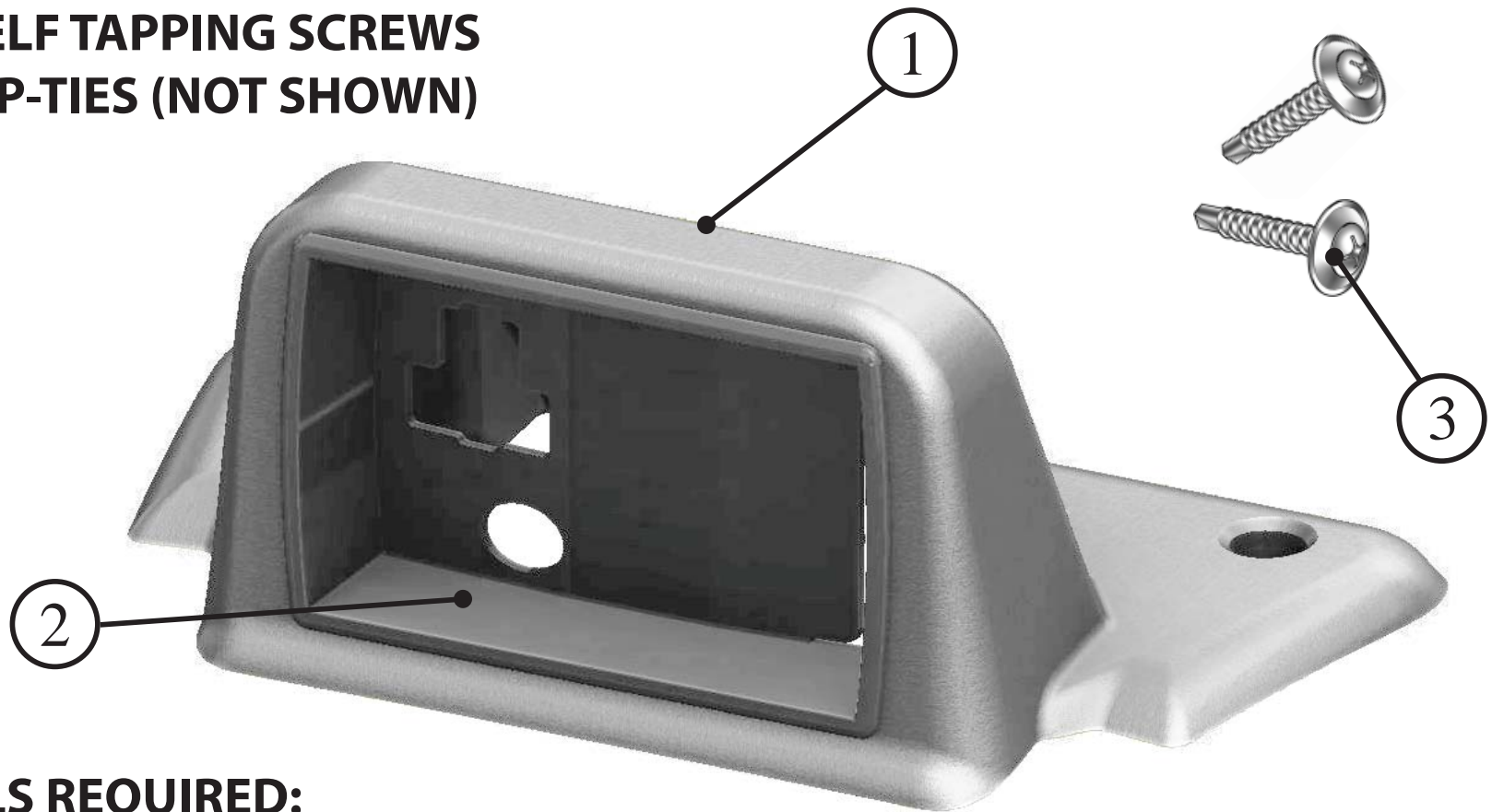

TOOLS REQUIRED:
#6 PHILLIPS HEAD SCREW DRIVER

2007-2010 JK WRANGLER KIT

- ① DASH POD
- ② RUBBER GROMMET
- ③ BEZEL CLIPS
- ④ VELCRO STRIP
- ⑤ ZIP-TIES (NOT SHOWN)

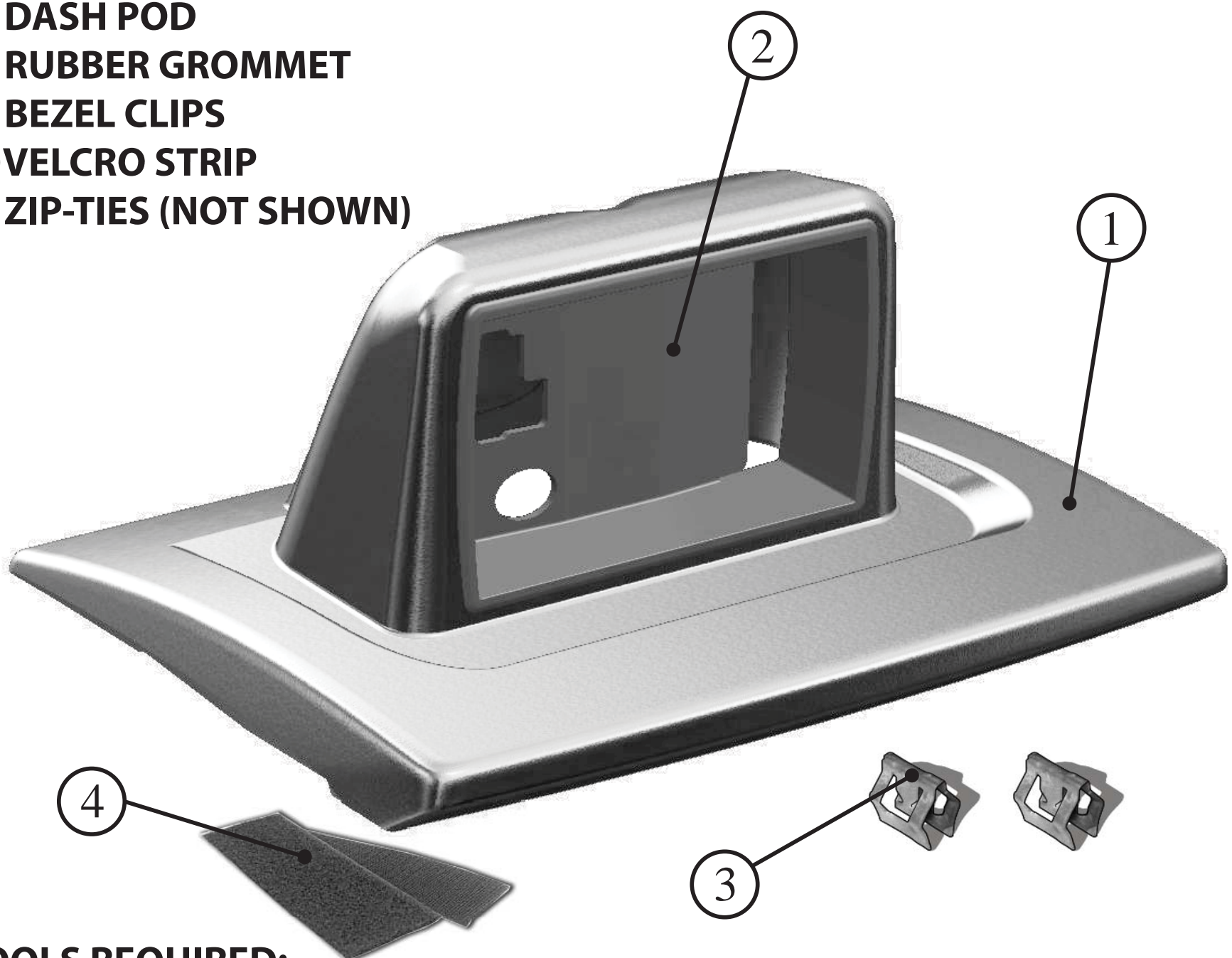

TOOLS REQUIRED:
-FLAT HEAD SCREW DRIVER -7MM SOCKET/WRENCH
-PHILLIPS HEAD SCREW DRIVER
-NEEDLE NOSE PLIERS

1997-2006 INSTALL

STEP 1 - TOP INSERT REMOVAL



Remove the rubber insert located in the bottom of the dash-top tray. This will need to be removed in order for the pod to be properly fastened into place.

STEP 2 - ROUTING THE CABLES

Route any cables up and behind the dash console as shown (The OBDII Cable is shown in this view).

Unscrew the highlighted panel and remove for easy access. This is the easiest way to route your cables.

REMOVE PANEL

Once the cables have been routed from the bottom of the dash to the top, the panel may be reinstalled.

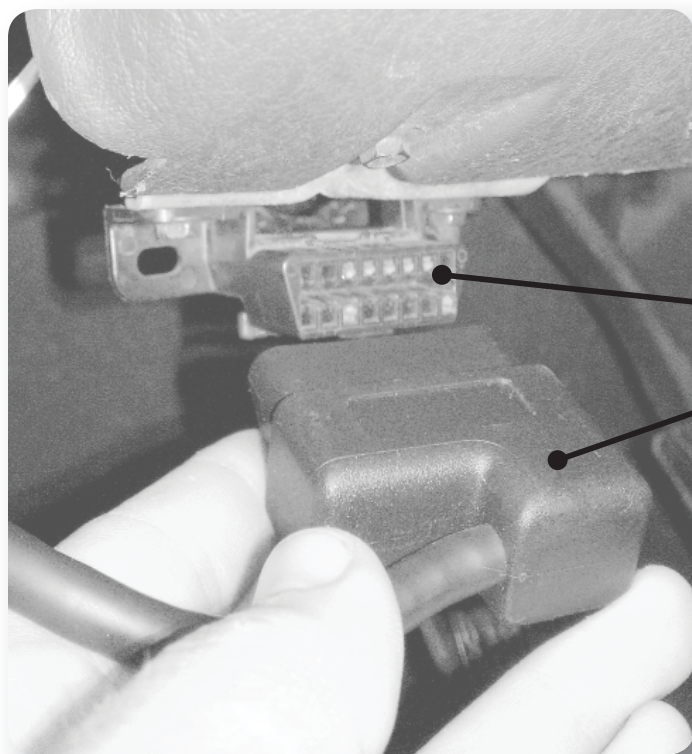
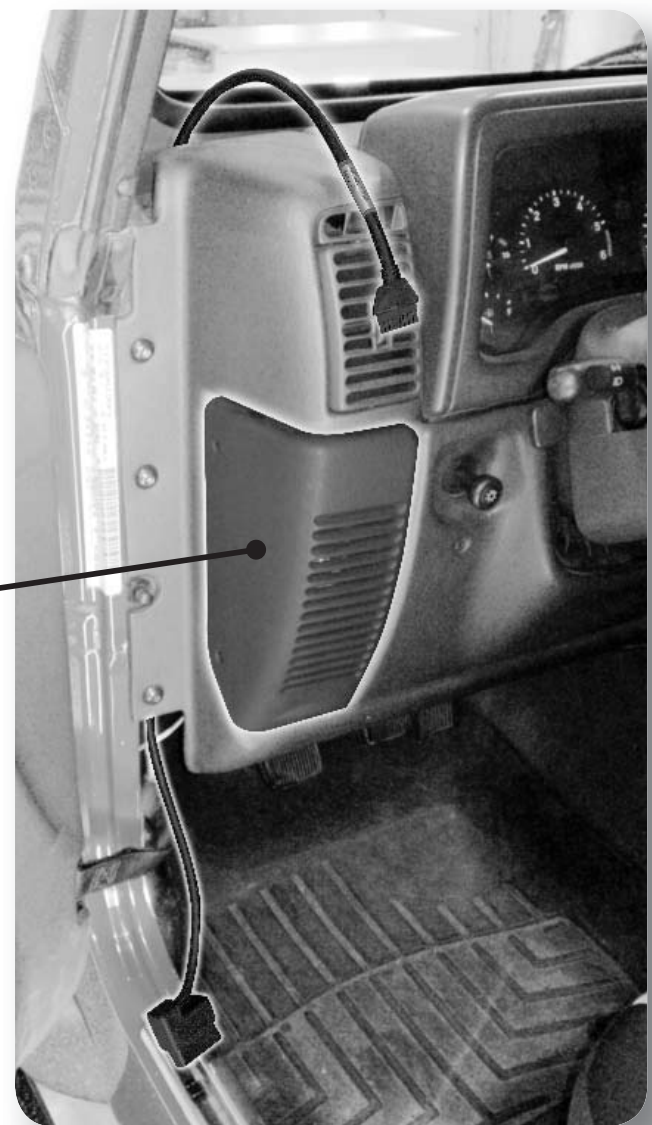

Next, locate the OBDII port underneath the dash. Plug the OBDII cable into the OBDII port.

VEHICLE OBDII PORT

OBDII CABLE

NOTE: If you have an EAS device, or a camera, refer to their individual installation manuals for more information on connection and routing instruction.

STEP 2 - ROUTING THE CABLES CONT'D

Continue to route the cables along the top of the dash console. To hide the cables, tuck them underneath the backside of the dash.

Next, position the pod on the dash top as shown.

On the back of the pod, there is a slot which allows the cable to exit.

NOTE: The pod will sit flush against the dash with little to no gap as long as the cables are not interfering.

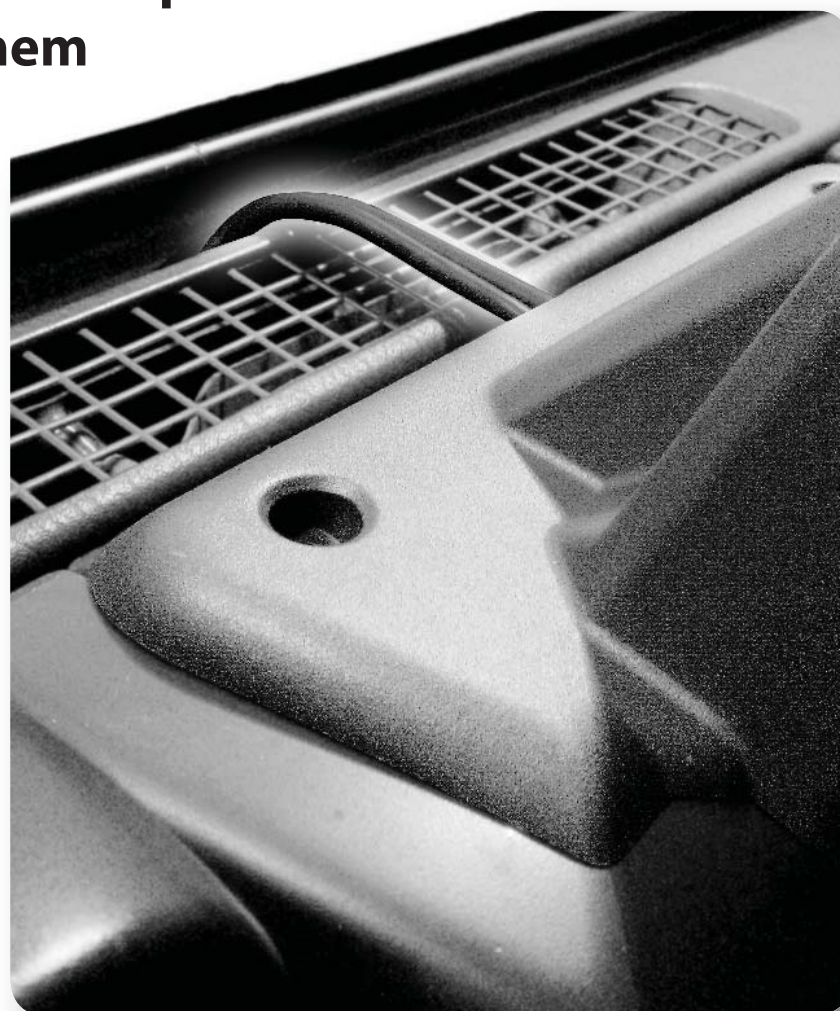

STEP 3 - FINAL POD INSTALLATION

Insert each routed cable through the provided holes located in the rubber grommet as shown. Depending on what you have purchased, will depend on what cables you have routed. This example shows all three cables.

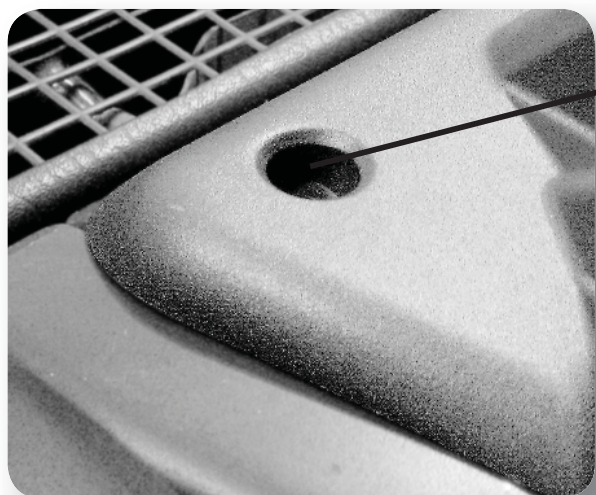
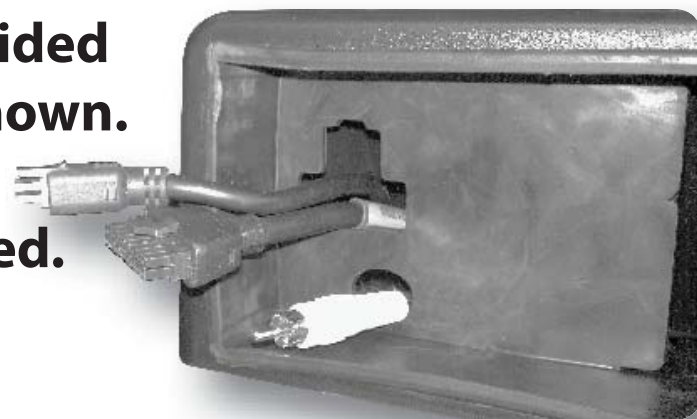

Next, using the provided self-tapping screws, fasten the pod to the dash. **DO NOT OVERTIGHTEN**

NOTE: Prior to inserting the screws, make sure the pod is sitting tight/flush with the dash top.

NOTE: Prior to inserting the device into the pod, we recommend lightly lubricating the top, bottom, and sides of the rubber grommet with petroleum based grease/lubricant (it doesn't take much). This is necessary for later removal of the device when updating or safe keeping.

STEP 3 - FINAL POD INSTALLATION CONT'D

Once the pod has been fastened to the dash top, plug the routed cable connectors into the backside of the TrailDash device.

Press the device into the pod until the front face of the pod grommet is flush with the front of the TrailDash device.

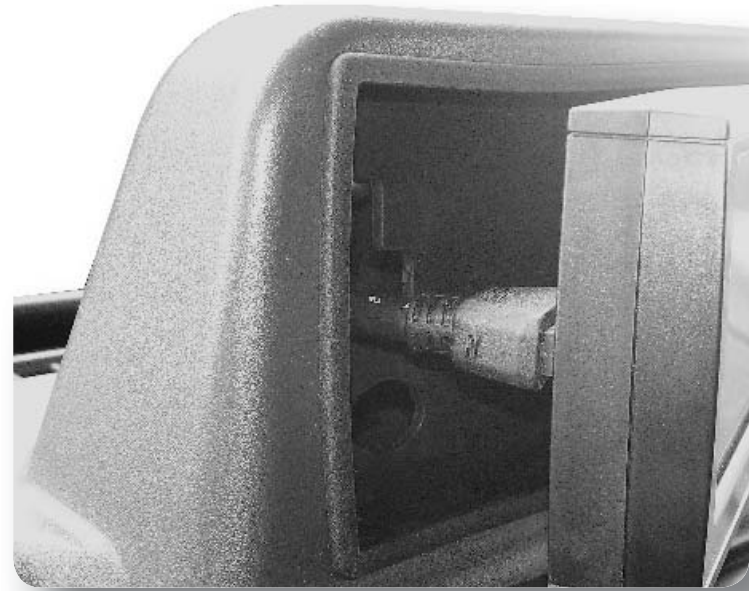

DEVICE REMOVAL

To remove the TrailDash device from the pod, press firmly on the side shown. This will pivot the device within the pod and expose the side closest to the driver. Continue this motion until you are able to grab the exposed side and remove the device from the pod.



STEP 1 - TOP PANEL REMOVAL



In order to install your new pod, the top dash panel located above the center console will first need to be removed.

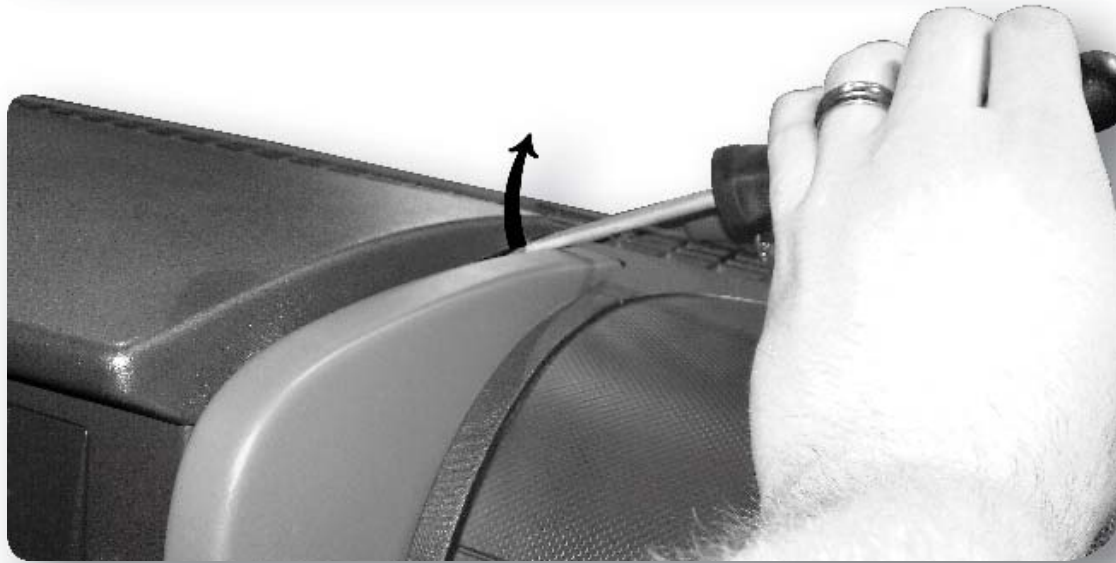

The panel is held in place by clips located on each side closest to the windshield. Insert a flat head screw driver underneath each side and pry up on the panel until the clip is released.

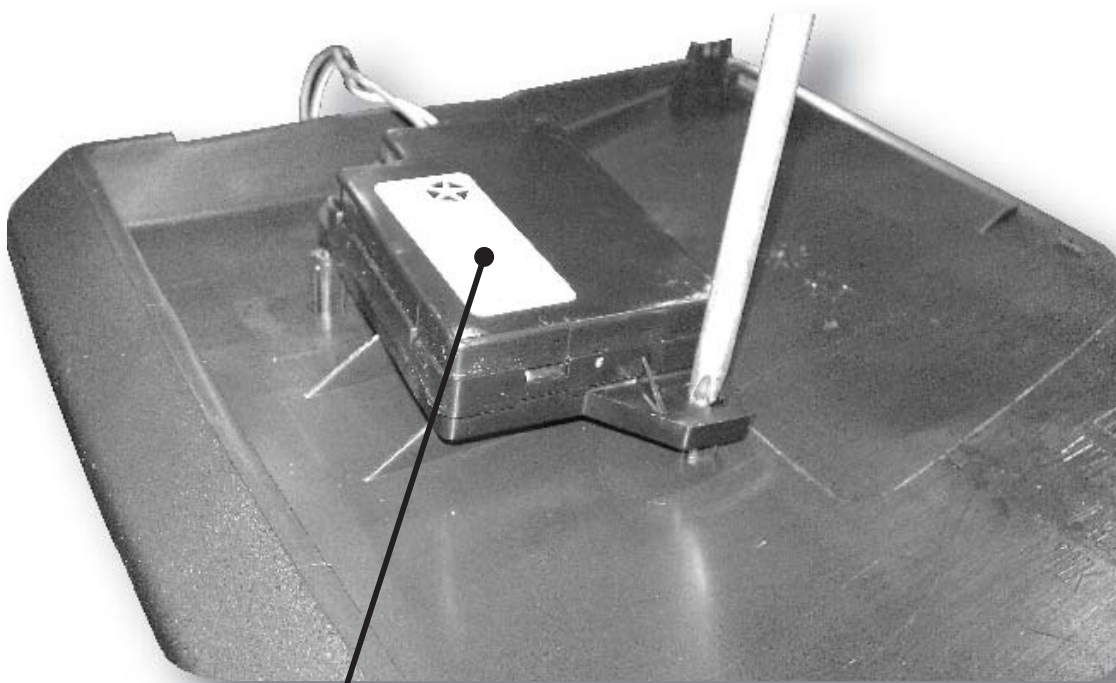

Using a Phillips head screwdriver, remove the compass module located on the bottom side of the panel you have just removed.

The compass module will be reinstalled later using Velcro strips provided in your kit.



Place the Velcro as shown over the white label located on the side shown. Set the module aside for later install.

STEP 2 - FRONT PANEL REMOVAL



Remove these screws using a 7mm socket or wrench. Set aside.

NOTE: The front console panel will need to be pulled away from the dash in order to properly route the cables.



Remove lower panel using the screw driver method as shown in step 1 to expose the screws.



Remove the (2) screws shown using a 7mm socket or wrench.

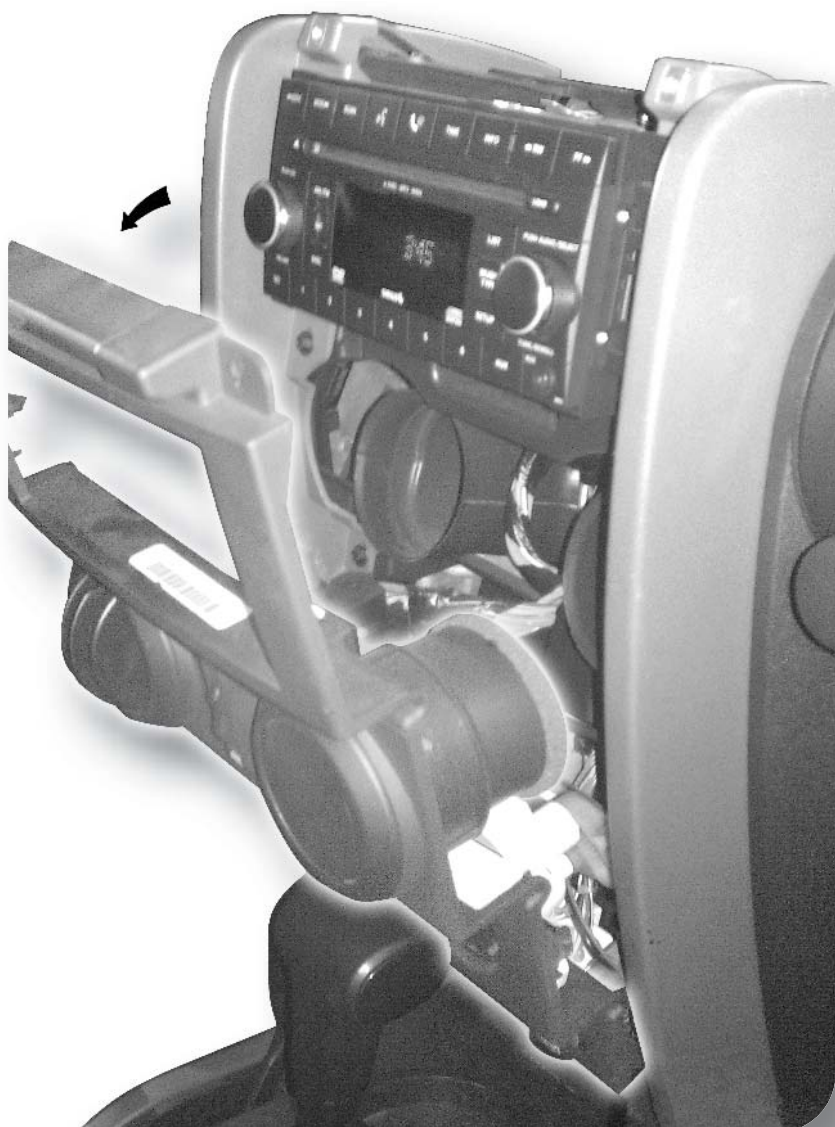

Starting from the top, pull the front panel back and away from the dash.

NOTE: There are clips that hold the panel to the dash similar to those located on the bottom side of the top panel you removed in Step 1.

Pulling this panel back will give you easy access for routing the cable.

STEP 3 - DRIVER SIDE PANEL REMOVAL

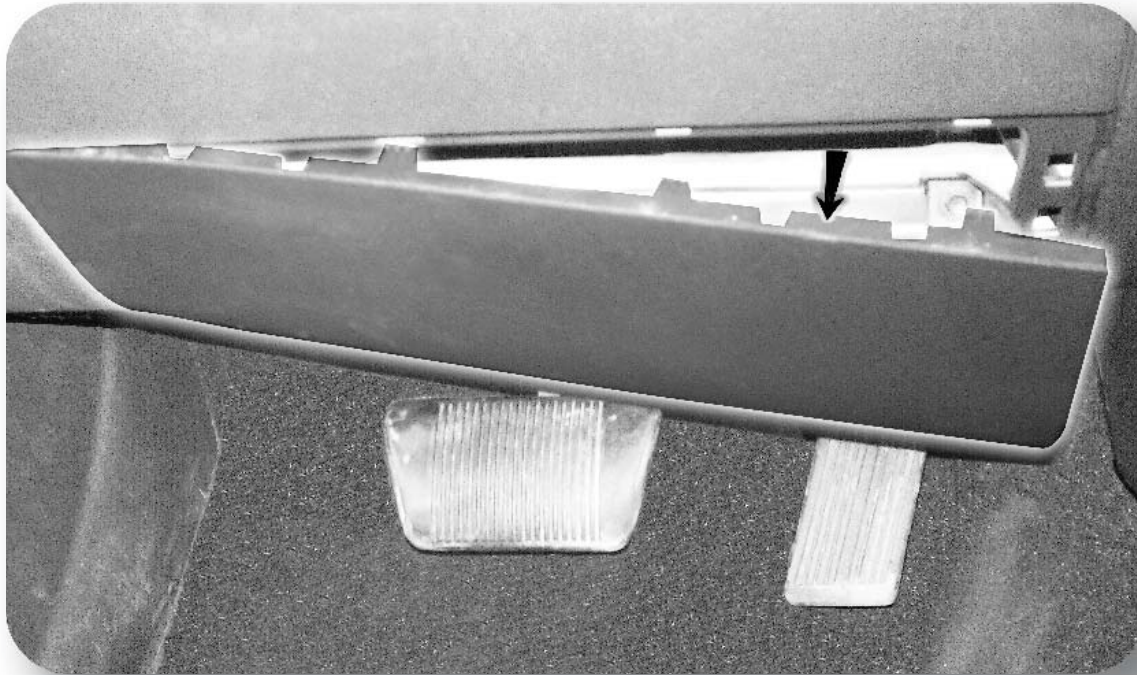

Remove the lower dash panel located directly above the foot pedals.

Pry from the top with the flat head screw driver until the clips are released.



Next, remove the panel directly under the steering column.

Similar to before, this panel is held on by clips. If needed, use the flat head screw driver to pry the panel away from the dash console.

STEP 4 - ROUTING THE CABLES

NOTE: This step can be followed for any other cables reaching up to the Dash Pod such as EAS or Camera cables.



Route the cable from underneath the steering column, and through the side of the center panel area as shown.

STEP 4 - ROUTING THE CABLES CONT'D



Next, route the cable up and along the side of the radio as shown.

NOTE: *If you have multiple cables, use both sides of the radio as a path for routing. This will help with any interference issues when the front panel is re-installed.*



Once the cable has been routed up to the dash top, the OBDII connector can be routed and plugged into the OBDII port located on the left side of the dash as shown.

Next, replace all panels, except the top panel removed in step 1.

STEP 5 - COMPASS MODULE PLACEMENT



Do not place directly on top of radio. Install exactly as shown. The white label is down, and the wires are on the driver side.

CENTER THE COMPASS MODULE ON THE DASH.

ALIGN THE BACK SIDE OF THE MODULE WITH THE LINE SHOWN.

STEP 6 - RETAINING CLIP INSTALLATION

METAL CLIP



PLASTIC TAB

Insert a metal clip over each of the pod tabs as shown. Allow the small "teeth" on both sides of the clip to pierce into the plastic. Use a pair of needle nose pliers to help seat them if needed. Refer to the original panel for a visual of how these should be installed.

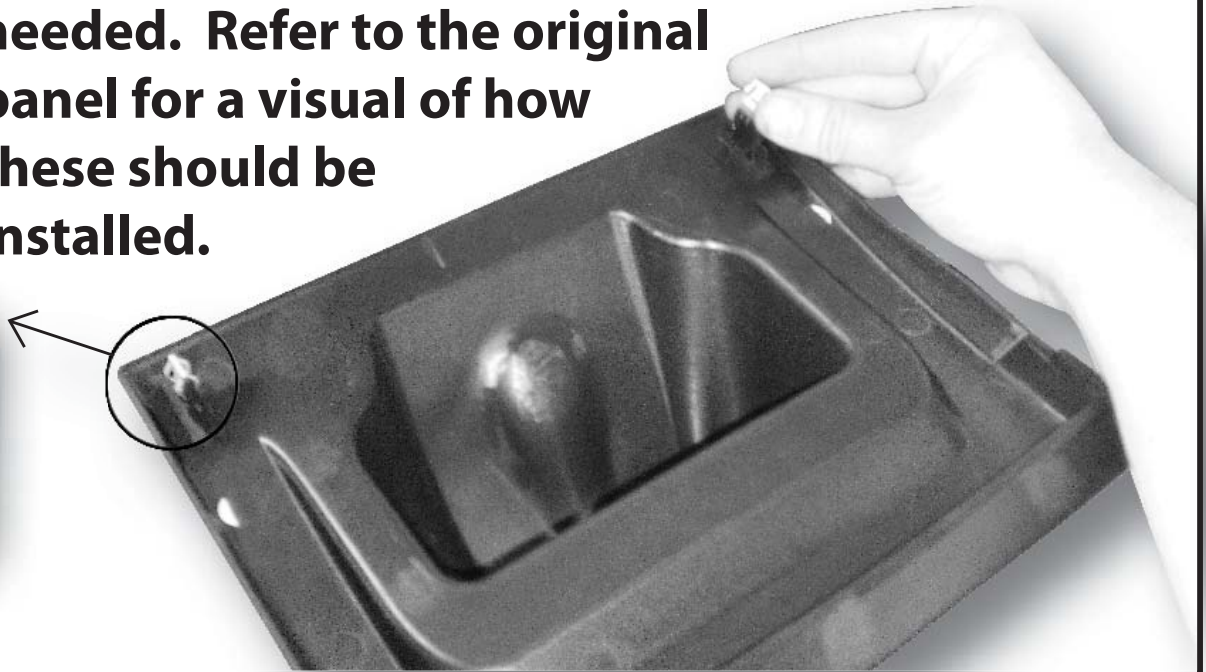

STEP 7 - FINAL POD INSTALLATION

Insert each routed cable through the provided holes located in the rubber grommet as shown. Depending on what you have purchased, will depend on what cables you have routed. This example shows all three cables.

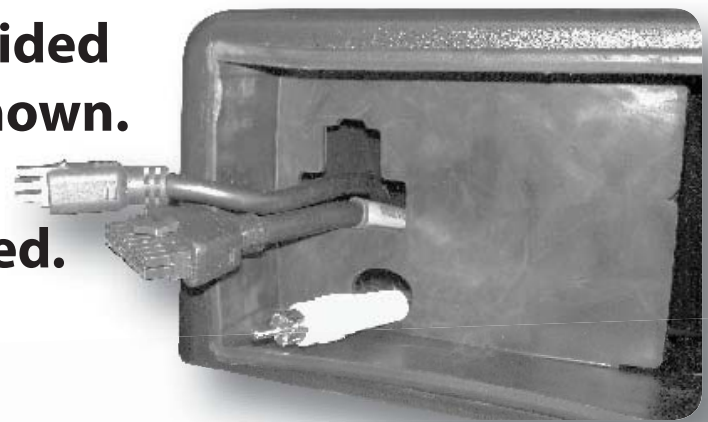

Located on top of the front dash panel is a protruding feature that will fit inside the slotted pod feature. This fit will need to take place prior to snapping in the back half of the pod.

Slide the pod into position allowing the dash feature to fit inside as shown in the cut out view.

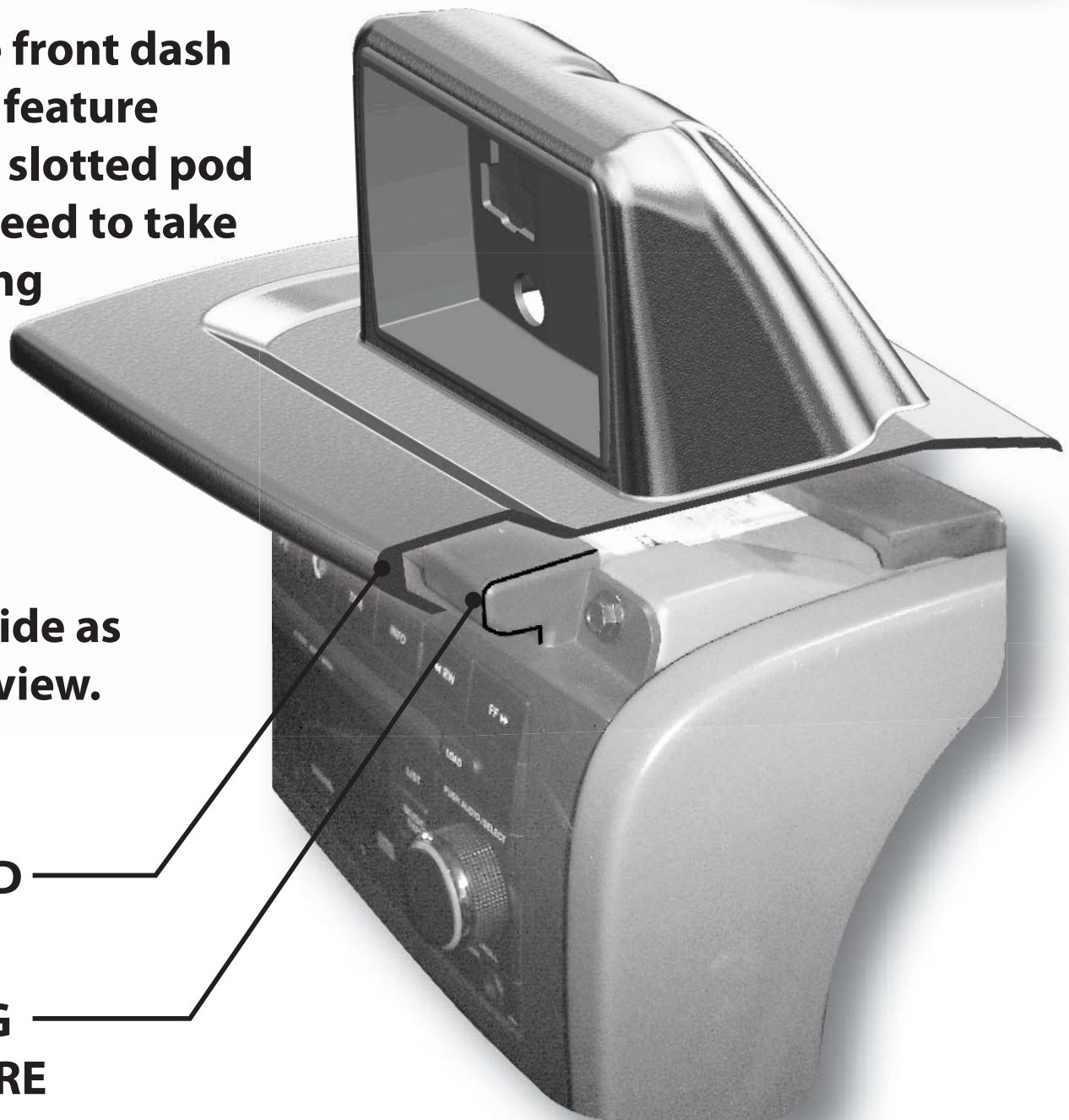

SLOTTED POD FEATURE

PROTRUDING DASH FEATURE

STEP 7 - FINAL POD INSTALLATION CONT'D

Press each snap down on both sides until you hear and feel the clip engage with the dash.

Lightly pull up on the pod to ensure that it has properly seated.

NOTE: Prior to inserting the device into the pod, we recommend lightly lubricating the top, bottom, and sides of the rubber grommet with petroleum based grease/lubricant (it doesn't take much). This is necessary for later removal of the device when updating or safe keeping.



Once the pod has been fastened to the dash top, plug the routed cable connectors into the backside of the TrailDash device.

Press the device into the pod until the front face of the pod grommet is flush with the front of the TrailDash device.

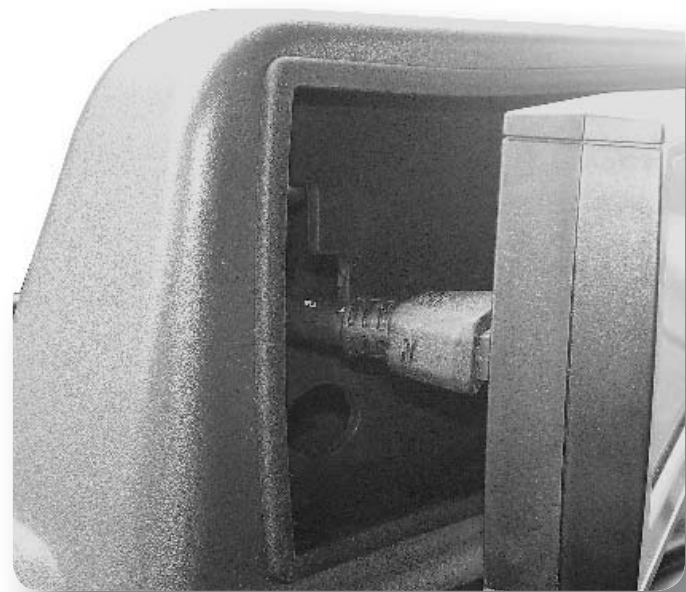

NOTE: For instructions on how to remove the device from the pod, refer to page 5 of this manual.

Follow Us



www.superchips.com

Superchips[®]